



Classroom Technology Guide

Columbia State Community College

**Instructional Technology Support Services
Waymon L. Hickman Building, Room 131
1665 Hampshire Pike
Columbia, TN 38401**

Bob Trybalski, Coordinator
rtrybalski@columbiastate.edu
931.540.2869

Stewart Marston, Electronic Media Technician
smarston@columbiastate.edu
931.540.2888

Control Panel

How to Turn ON/OFF the Projector and Other Functions



DISPLAY: **ON** - Turns on the projector and lowers the screen
(**Warning:** 90 second warm up time; wait for ON button to stop blinking)

OFF - Turns off the projector and raises the screen

VOLUME: Turn the knob to the right to increase volume.
Turn it to the left to decrease volume.
(Green lights to the left of knob will light up as volume increases.)

PIC MUTE: Press the PIC MUTE button to blank the screen. The light illuminates red.

AUTO IMAGE: Press the AUTO IMAGE button if the computer or laptop display does not look normal on the projector screen.

CC ON/OFF: Press the CC button to turn on the closed caption decoder for the DVD/VHS player. Press again to turn off this feature. This does not decode closed captioned media on the computer.

SELECTING A DEVICE FOR PROJECTION: Press one of the following buttons to project that device.

1 - DOC Camera (document camera)

2 - LAPTOP

3 - PC

4 - VIDEO or DVD/VCR (to project the DVD/VHS player)

5 - AUX VIDEO. Press the AUX VIDEO button when you connect an external video device's RCA output to the external video ports on the hideaway.

6 - AUX S-VIDEO. Press the AUX S-VIDEO button when you connect an external video device's s-video output to the S-Video port on the hideaway. The RCA audio output of the s-video device must be plugged into the RCA port on the hideaway if audio output is needed.

Document Camera

(Commonly referred to by brand name: Elmo)

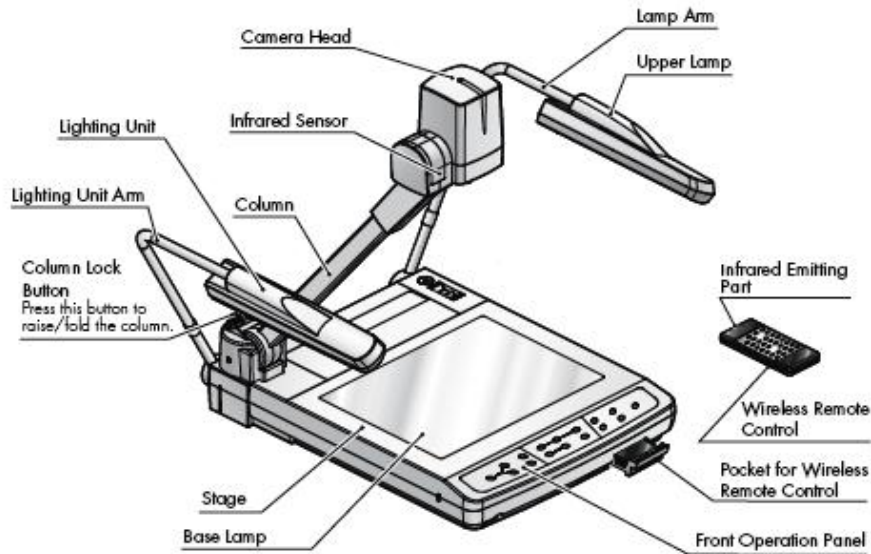

Front Operation Panel

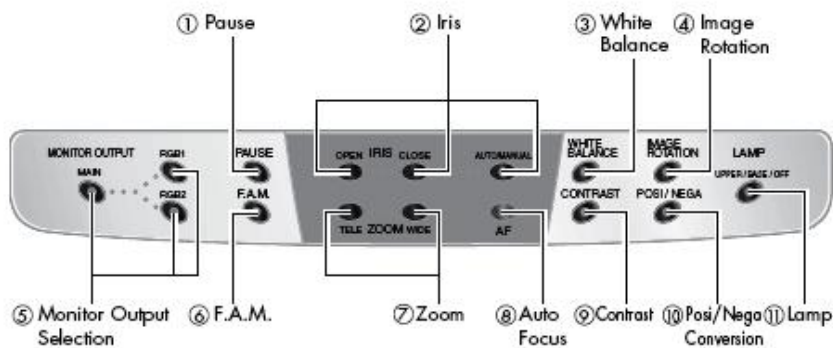

	Name	Function
①	Pause	To pause the image.
②	Iris	To adjust the brightness of the screen.
③	White Balance	To change the mode between AUTO and ONE-PUSH.
④	Image Rotation	To rotate the image. Every time this button is pressed, the image rotates counterclockwise by 90°.
⑤	Monitor Output Selection	To change the output line.
⑥	F.A.M. (Frame Accumulate Mode)	To select F.A.M.
⑦	Zoom	To zoom the object.
⑧	Auto Focus	To focus automatically.
⑨	Contrast	To make documents, etc. visible clearly.
⑩	Posi/Nega Conversion	To switch Posi/Nega.
⑪	Lamp	To switch the lighting.

Document Camera Continued

(Commonly referred to by brand name: Elmo)

Elmo Remote Control

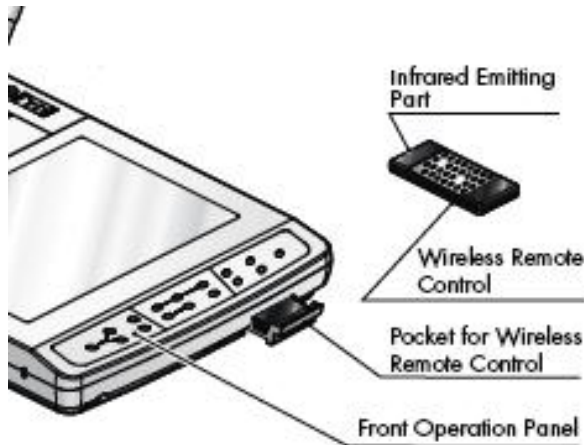

The Elmo remote control has all of the functions of the Front Operation Panel with added functions to make operation easier.

Button Name		Function
1	PAUSE	To pause the image.
2	ELECTRONIC ENLARGEMENT	2X To double the image size.
3		ARROWS To scroll the electronic enlargement screen. When the video pointer is displayed, this can also be used to move the video pointer.
4	MEMORY NO.	The memory No. Used with [5] to [8].
5	STATUS	PRESET-SET To store the operating condition of the equipment. Used with the memory No.
6		PRESET-CALL To call the stored operating condition then. Used with the memory No.
7	IMAGE	IMAGE-SET To store images in the main unit memory. Used with the memory No.
8		IMAGE-CALL To call the image stored by [IMAGE-SET] button. Used with the memory No.
9	POSI/NEGA	To switch POSI/NEGA.
10	COLOR/B&W	To switch COLOR/B&W.
11	LAMP	UPPER To turn ON/OFF the upper lamp.
12		BASE To turn ON/OFF the base lamp.
13	MONITOR OUTPUT	MAIN To change the output line.
14		RGB1
15		RGB2
16	ZOOM	TELE To zoom in.
17		WIDE To zoom out.
18	FOCUS	NEAR To move the focus near.
19		FAR To move the focus far.
20		AUTO FOCUS To focus automatically.
21	IRIS	NORMAL To reset the AUTO iris to the initial value.
22		OPEN To open the AUTO/MANUAL iris.
23		CLOSE To close the AUTO/MANUAL iris.

Wireless Remote Control

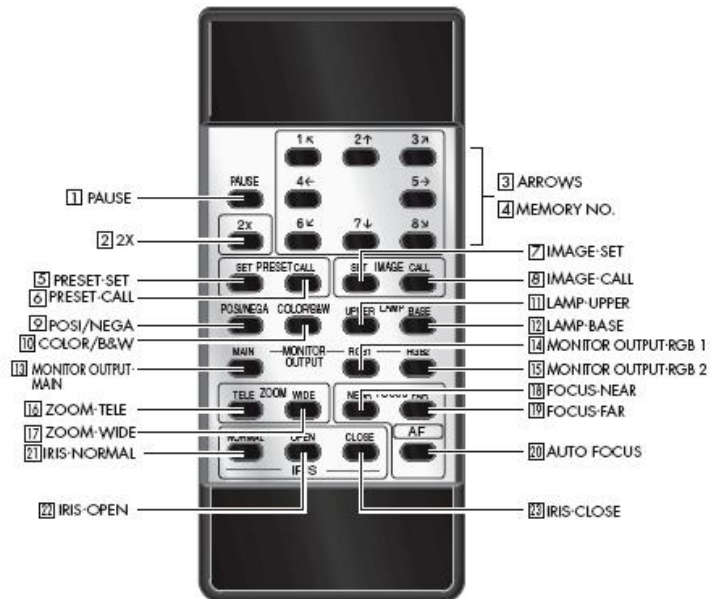

DVD/VHS Combination Player









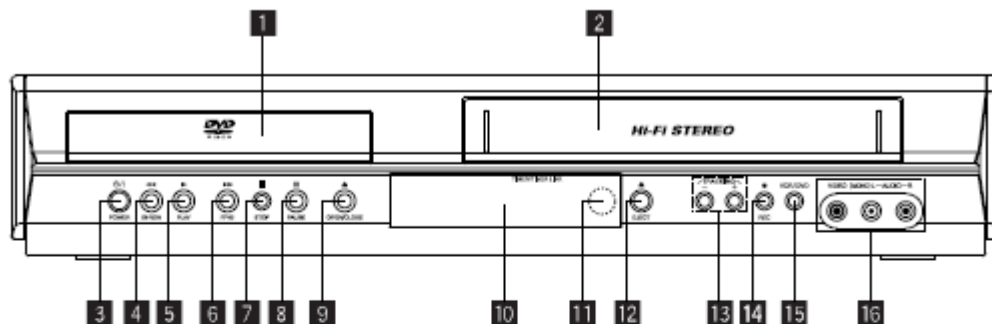

The College uses two different brands of DVD/VHS player; JVC and LG. Each of these players functions basically the same, and are no different than a consumer model you may have at home. The DVD/VHS player is located inside the equipment cabinet.

Each unit has a remote control located in the teacher station drawer.



Front Panel











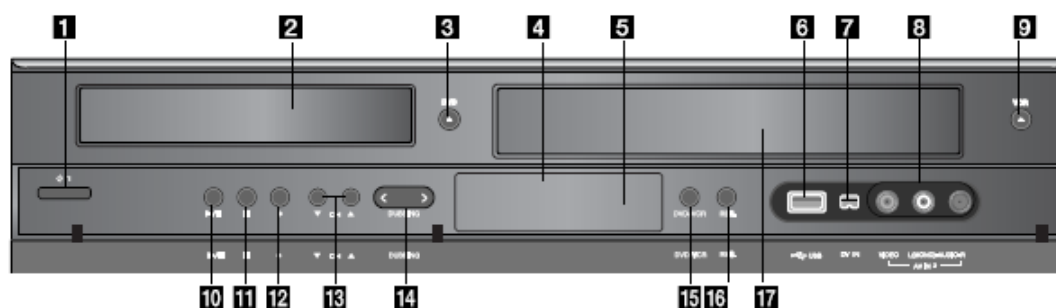



- | | |
|---|---|
| <p>1 Disc Tray (DVD deck)
Insert a disc here.</p> <p>2 Cassette Compartment (VCR deck)
Insert a video cassette here.</p> <p>3 POWER 
Switches the unit ON and OFF.</p> <p>4 REW 
- DVD: Skip to beginning of current chapter or track, press twice in quick successions to go to previous chapter or track. Press and hold button for about two seconds to search backward.
- VCR: Rewinds the tape during the stop mode or for fast reverse picture search.</p> <p>5 PLAY 
Starts playback of a disc or tape.</p> <p>6 FF 
- DVD: Skip to next chapter or track. Press and hold for two seconds for a fast forward search.
- VCR: Advances the tape during the STOP mode or for fast forward picture search.</p> <p>7 STOP 
Stops playback of the disc or tape.</p> | <p>8 PAUSE 
Pause playback or recording. Press repeatedly for frame-by-frame playback.</p> <p>9 OPEN/CLOSE 
Opens or closes the disc tray.</p> <p>10 Display Windows</p> <p>11 Remote Sensor
Point the unit Remote Control here.</p> <p>12 EJECT 
Ejects the tape in the VCR deck.</p> <p>13 TRACKING \pm
To adjust tracking.</p> <p>14 REC 
To record normally or to activate One-touch Timer Recording by repeated presses. Press REC  for more than 3 seconds to set the unit to standby mode for Timer-Link recording.</p> <p>15 VCR/DVD (output select)
Select one of your output sources to view on the TV screen between DVD and VCR.</p> <p>16 LINE2 (VIDEO/AUDIO (L/R) input)
Connect to the audio/video output of an external source (Audio system, TV/Monitor, Another VCR).</p> |
|---|---|

DVD/VHS Combination Player Continued (LG Model)



Front Panel



- | | |
|---|---|
|  | Lights when a disc is in the DVD deck. |
| DVD | The DVD deck is selected. |
|  | Lights when the Recorder is in playing mode or flashes when search mode. |
| VCR | The VCR deck is selected. |
|  | Indicates when the recorder is in timer recording or a timer recording is programmed. |
|  | A Video tape is inserted in the VCR deck. |
| REC | The Recorder is recording. |
| PM | Indicates PM time. (AM is not displayed.) |
- 1**  / I (POWER)
Switches the Recorder ON and OFF.
 - 2** Disc Tray (DVD deck)
Insert a disc here.
 - 3**  DVD
Opens or closes the disc tray.
 - 4** Display window
Shows the current status of the Recorder.
 - 5** Remote Sensor
Point the recorder Remote Control here.
 - 6** USB Port
Connect an USB Flash Drive.
 - 7** DV IN
Connect the DV output of a digital camcorder.
 - 8** AV IN 2 (VIDEO /AUDIO (Left/Right))
Connect the audio/video output of an external source (Audio system, TV/ Monitor, VCR, Camcorder, etc.).
 - 9**  VCR
Ejects the tape in the VCR deck.
 - 10**  (PLAY / PAUSE)
Starts playback.
Pause playback or recording temporarily, press again to exit pause mode.
 - 11**  (STOP)
Stops playback
 - 12**  (REC)
Starts recording.
Press repeatedly to set the recording time.
 - 13** CH ( / )
Scans up or down through memorized channels.
 - 14** DUBBING
Press to copy DVD to VCR (or VCR to DVD).
Lights when the Recorder is dubbing.
 - 15** DVD/VCR
Toggles control between the DVD deck and the VCR deck.
 - 16** RES.
Sets the output resolution for HDMI and COMPONENT OUTPUT jacks.
- HDMI: 1080p, 1080i, 720p, 480p, 480i
- COMPONENT: 480p, 480i
 - 17** Cassette Compartment (VCR deck)
Insert a video cassette here.

Extron Hideaway (External USB ports, and Laptop Connections)

The Extron Hideaway provides external connections for the PC's USB ports, laptop connection, and external audio/visual devices (cameras, I-pods, MP3 players, and etcetera).

Notice in the pictures below that one type of hideaway has more capabilities, but each essentially provide the same basic functions.

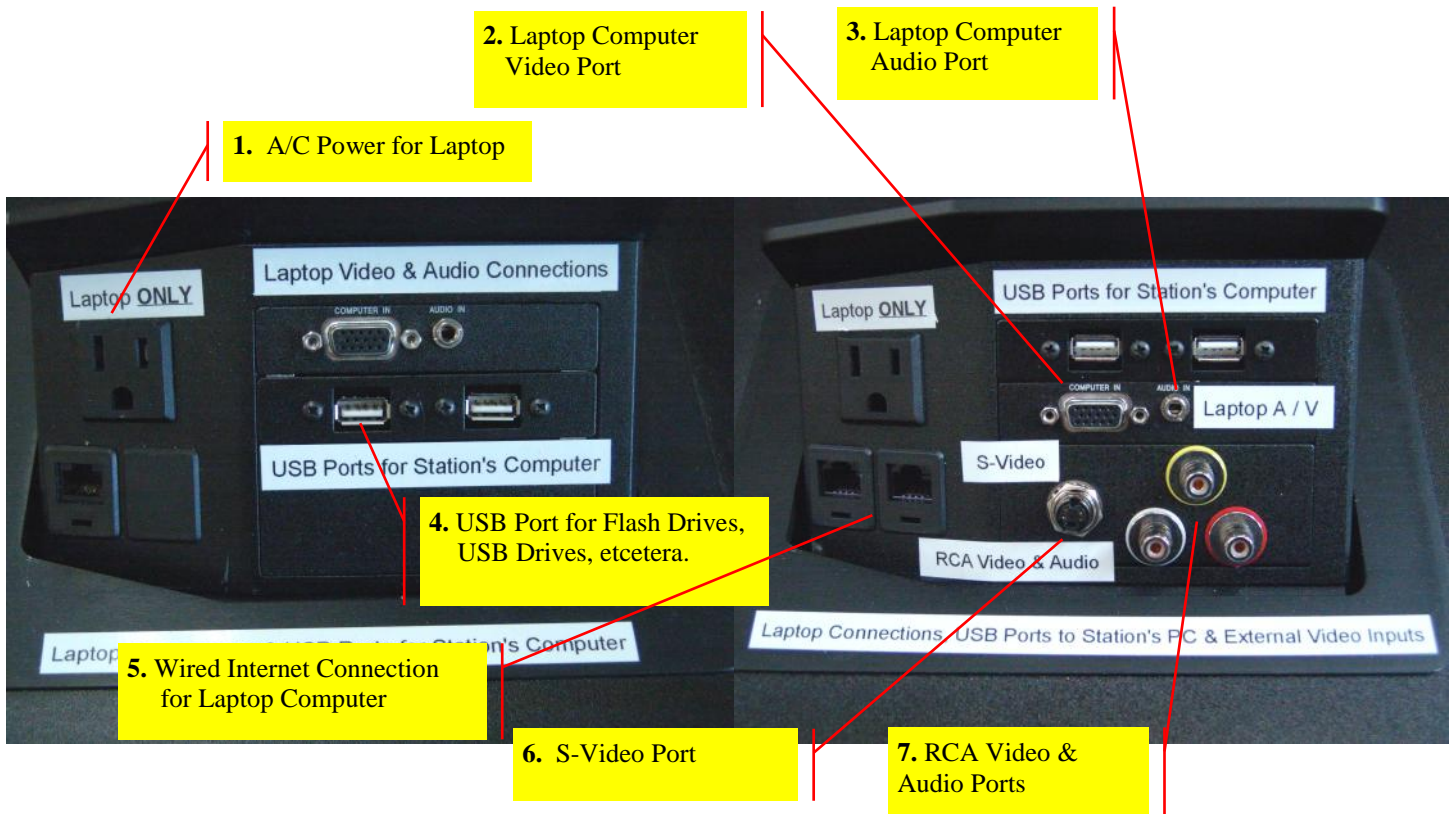

1. **A/C Power** for Laptop provides 110V power.
2. **Laptop Computer Video Port.** Connect one end of VGA Cable into this port and the other end into a similar looking port on your laptop. Press ON to lower screen and power on projector. Select Laptop on the control panel to see the laptop computer's video on projection screen. TIP: If the video looks "cut off" on the screen, press AUTO IMAGE on the control panel.
3. **Laptop Computer Audio Port.** Plug one end of mini audio jack into this port and the other end into a similar looking port on your laptop. You can also plug an I-Pod or MP3 player into this port. Select Laptop on control panel to hear the audio. TIP: Use the volume knob on the control panel to adjust the audio level.
4. **USB Port for Flash Drives, USB Drive, etcetera.** Connect your USB device here for the teacher station's PC.
5. **Wired Internet Connection for Laptop Computer.** Connect one end of your internet cable to this port and the other to a similar looking port on your laptop computer.
6. **S-Video Port.** Connect one end of your S-Video cable to your camera or external video device and the other end to the S-Video port on the hideaway. Press AUX S-Video or S-VIDEO on the control panel to project.
7. **RCA Video & Audio Ports.** Connect the yellow video wire to the yellow port, the white left channel audio wire to the white port, and the red right channel audio wire to the red port. Press VIDEO or AUX VIDEO on the control panel to project.

Having difficulties with equipment in the classroom?

The following troubleshooting guide may help to solve the problem. Further assistance, including a personal tutorial session, may be arranged by contacting Bob Trybalski, Coordinator, Instructional Technology Support Services at (931) 540-2869 or rtrybalski@columbiastate.edu.

Cabinet doors locked?

- The keys should be next to the computer keyboard or in the drawer.

None of the equipment is working!

- Is the master power switch, located inside the cabinet, on?
- Are all the components inside the cabinet turned on?

Projector Problems

- Have you turned on the projector using the control panel? It is a black box mounted on the countertop. Look for the "ON" button .
- Have you selected the correct input source? Press the button on the control panel that corresponds with the device you are using.

Screen Problems

- The screen will automatically lower when you press the "ON" button on the countertop control panel.
- Try pressing the "ON" button again after the projector is on and the button stops blinking.

Computer Problems

- Have you turned the computer power on?
- Have you turned on the power to the monitor?
- Have you "logged on" to the network?
- Is the computer not projecting? Check to see if the projector is turned on and the correct input source (PC) is selected on the control panel.
- Volume problem? Use the control panel's volume knob to adjust the sound.
- Double-click the speaker icon on the computer's taskbar to adjust the output volume and un-check the mute box.

Document Camera/Visual Presenter (Elmo)

- Is the power turned on? On some models, the power switch is located in the rear of the document camera near the power cord.
- Is the document camera not projecting? Check to see if the projector is turned on and the correct input source (DOC CAM) is selected on the control panel.
- Is the document dark? Check to see if the upper lamps are turned on. Also, you may need to adjust the iris.
- Is the document bright? Try turning off the upper lamps and/or adjusting the iris.
- Is the transparency dark? Check to see if the base lamp is turned on and try adjusting the iris. If your document camera does not have a base lamp, check to see if the upper lamps are on and/or try adjusting the iris.
- Is the transparency bright? Try turning off the base lamp or the upper lamp and adjusting the iris.
- Is the document or transparency out of focus? Try pressing auto-focus or manually adjusting the focus.
- Is the remote control's batteries dead? Contact Instructional Technology Support Services for new batteries.

TROUBLESHOOTING CONTINUED

VHS Machine

- Is the power turned on?
- Is there a tape in the machine?
- The machine will not play the tape. Have you tried another tape?
- Did you press VHS on the remote control or front of the machine?
- Is the VHS machine not projecting? Check to see if the projector is turned on and the correct input source (VIDEO or DVD/VCR) is selected on the control panel.
- Is the remote control's batteries dead? Contact Instructional Technology Support Services for new batteries.
- Volume problem? Use the control panel's volume knob to adjust the sound.

DVD Player

- Is the power turned on?
- Is there a DVD or CD in the machine?
- The machine will not play the disc. Have you tried another disc?
- Did you press DVD on the remote control or front of the machine?
- Is the DVD machine not projecting? Check to see if the projector is turned on and the correct input source (VIDEO or DVD/VCR) is selected on the control panel.
- Is the remote control's batteries dead? Contact Instructional Technology Support Services for new batteries.
- Volume problem? Use the control panel's volume knob to adjust the sound.